

ebm-papst Mulfingen GmbH & Co. KG  
 Bachmühle 2  
 D-74673 Mulfingen  
 Phone +49 (0) 7938 81-0  
 Fax +49 (0) 7938 81-110  
 info1@de.ebmpapst.com  
 www.ebmpapst.com

## CONTENTS

<b>1. SAFETY REGULATIONS AND NOTES</b>	<b>1</b>
1.1 Levels of hazard warnings	1
1.2 Staff qualification	1
1.3 Basic safety rules	1
1.4 Electrical voltage	1
1.5 Safety and protective functions	2
1.6 Mechanical movement	2
1.7 Emission	2
1.8 Hot surface	2
1.9 Transport	2
1.10 Storage	2
1.11 Disposal	2
<b>2. PROPER USE</b>	<b>3</b>
<b>3. TECHNICAL DATA</b>	<b>4</b>
3.1 Product drawing	4
3.2 Nominal data	5
3.3 Data according to ErP directive	5
3.4 Technical features	5
3.5 Mounting data	5
3.6 Transport and storage conditions	5
<b>4. CONNECTION AND START-UP</b>	<b>6</b>
4.1 Connecting the mechanical system	6
4.2 Connecting the electrical system	6
4.3 Connection in terminal box	7
4.4 Connection screen	8
4.5 Open additional screwed cable glands	9
4.6 Checking the connections	9
4.7 Switch on device	9
4.8 Switching off the device	9
<b>5. MAINTENANCE, MALFUNCTIONS, POSSIBLE CAUSES AND REMEDIES</b>	<b>10</b>
5.1 Cleaning	10
5.2 Safety test	10

## 1. SAFETY REGULATIONS AND NOTES

Please read these operating instructions carefully before starting to work with the device. Observe the following warnings to prevent malfunctions or physical damage to both property and people.

These operating instructions are to be regarded as part of this device. If the device is sold or transferred, the operating instructions must accompany it.

These operating instructions may be duplicated and forwarded for information about potential dangers and their prevention.

### 1.1 Levels of hazard warnings

These operating instructions use the following hazard levels to indicate potentially hazardous situations and important safety regulations:



#### **DANGER**

Indicates an imminently hazardous situation which, if not avoided, will result in death or serious injury. Compliance with the measures is mandatory.

#### **WARNING**

Indicates a potentially hazardous situation which, if not avoided, could result in death or serious injury. Exercise extreme caution while working.

#### **CAUTION**

Indicates a potentially hazardous situation which, if not avoided, may result in minor or moderate injury or damage of property.

#### **NOTE**

A potentially harmful situation can occur and, if not avoided, can lead to property damage.

### 1.2 Staff qualification

The device may only be transported, unpacked, installed, operated, maintained and otherwise used by qualified, trained and authorised technical staff.

Only authorised specialists are permitted to install the device, to carry out a test run and to perform work on the electrical installation.

### 1.3 Basic safety rules

Any safety hazards stemming from the device must be re-evaluated once it is installed in the end device.

Observe the following when working on the unit:

- ⇒ Do not make any modifications, additions or conversions to the device without the approval of ebm-papst.

### 1.4 Electrical voltage

- ⇒ Check the electrical equipment of the device at regular intervals, refer to chapter 5.2 Safety test.

- ⇒ Replace loose connections and defective cables immediately.



#### **DANGER**

#### **Electrical load on the device**

Risk of electric shock

- Stand on a rubber mat if you are working on an electrically charged device.

#### **WARNING**

#### **Terminals and connections have voltage even with a unit that is shut off**

Electric shock

- Wait five minutes after disconnecting the voltage at all poles before opening the device.

**CAUTION**

**In the event of failure, there is electric voltage at the rotor and impeller**

The rotor and impeller are base insulated.

→ Do not touch the rotor and impeller once they are installed.

**CAUTION**

**The motor restarts automatically when operating voltage is applied, e.g. after a power failure.**

Danger of injury

→ Keep out of the danger zone of the device.

→ When working on the device, switch off the mains supply voltage and secure the latter from being switched on again.

→ Wait until the device stops.

→ Insert the brought-out thermal overload protector into the control circuit so that the cooled off motor does not switch on independently after a fault.

**1.5 Safety and protective functions****DANGER**

**Missing safety device and non-functioning safety device**

If there is no safety device, you could be seriously injured, for example if you reach into the running device or your hands are sucked into it.

→ Operate the device only with a fixed and isolating safety protection and a fixed guard grille.  
The guard must withstand the kinetic energy of a fan blade detaching at maximum speed.

→ The device is a built-in component. You, the owner/operator, are responsible for providing adequate protection for the device.

→ Shut down the device immediately if you detect a missing or ineffective protective feature.

**1.6 Mechanical movement****DANGER**

**Rotating device**

Body parts that come into contact with the rotor and impeller can be injured.

→ Secure the device against accidental contact.

→ Before working on the system/machine, wait until all parts have come to a standstill.

**WARNING**

**Rotating device**

Long hair, loose items of clothing and jewellery could become entangled and pulled into the device. You could be injured.

→ Do not wear any loose clothing or jewellery while working on rotating parts.

→ Protect long hair by wearing a cap.

**1.7 Emission****WARNING**

**Depending on the installation and operating conditions, a sound pressure level greater than 70 dB(A) may arise.**

Danger of noise-induced hearing loss

→ Take appropriate technical safety measures.

→ Protect operating personnel with appropriate safety equipment, e.g. hearing protection.

→ Also observe the requirements of local agencies.

**1.8 Hot surface****CAUTION**

**High temperature at the motor housing**

Danger of burn injuries

→ Ensure that sufficient protection against accidental contact is provided.

**1.9 Transport****NOTE**

**Transport of device**

→ Transport the device in its original packaging only.

→ Secure the device so that it does not slip, e.g. by using a clamping strap.

**1.10 Storage**

⇒ Store the device, partially or fully assembled, in a dry and weatherproof manner in the original packing in a clean environment.

⇒ Protect the device from environmental impacts and dirt until the final installation.

⇒ We recommend storing the device for a maximum up to one year to guarantee proper operation and longest possible service life.

⇒ Even devices explicitly suited for outdoor use are to be stored as described prior to being commissioned.

⇒ Maintain the storage temperature, see chapter 3.6 Transport and storage conditions.

⇒ Please make sure that all screwed cable glands are fitted with dummy plugs.

**1.11 Disposal**

When disposing of the device, please comply with all relevant requirements and regulations applicable in your country.

## 2. PROPER USE

The device is exclusively designed as a built-in device for conveying air according to its technical data.

Any other usage above and beyond this does not conform with the intended purpose and constitutes misuse of the device.

Customer equipment must be capable of withstanding the mechanical and thermal stresses that can arise from this product. This applies for the entire service life of the equipment in which this product is installed.

### Proper use also includes:

- Only using the device in stationary systems.
- Carrying out all maintenance.
- Moving air with a density of 1.2 kg/m<sup>3</sup>.
- Using the device in accordance with the permitted ambient temperature, see chapter 3.6 Transport and storage conditions and chapter 3.2 Nominal data.
- Operating the device with all protective features in place.
- Minding the operating instructions.

### Improper use

Using the device in the following ways is particularly prohibited and may cause hazards:

- Operating the device with an imbalance, e.g. caused by dirt deposits or icing.
- Operation in medical equipment with a life-sustaining or lifesaving function.
- Operation with external vibrations.
- Moving solids content in flow medium.
- Painting the device
- Connections (e.g. screws) coming loose during operation.
- Opening the terminal box during operation.
- Moving air that contains abrasive particles.
- Moving highly corrosive air, e.g. salt spray mist. Exceptions are devices that are intended for salt spray mist and protected accordingly.
- Moving air that contains dust pollution, e.g. suctioning off saw dust.
- Operating the device close to flammable materials or components.
- Operating the device in an explosive atmosphere.
- Using the device as a safety component or for taking on safety-related functions.
- Operation with completely or partially disassembled or modified protective features.
- In addition, all application options that are not listed under proper use.

## 3. TECHNICAL DATA

## 3.1 Product drawing

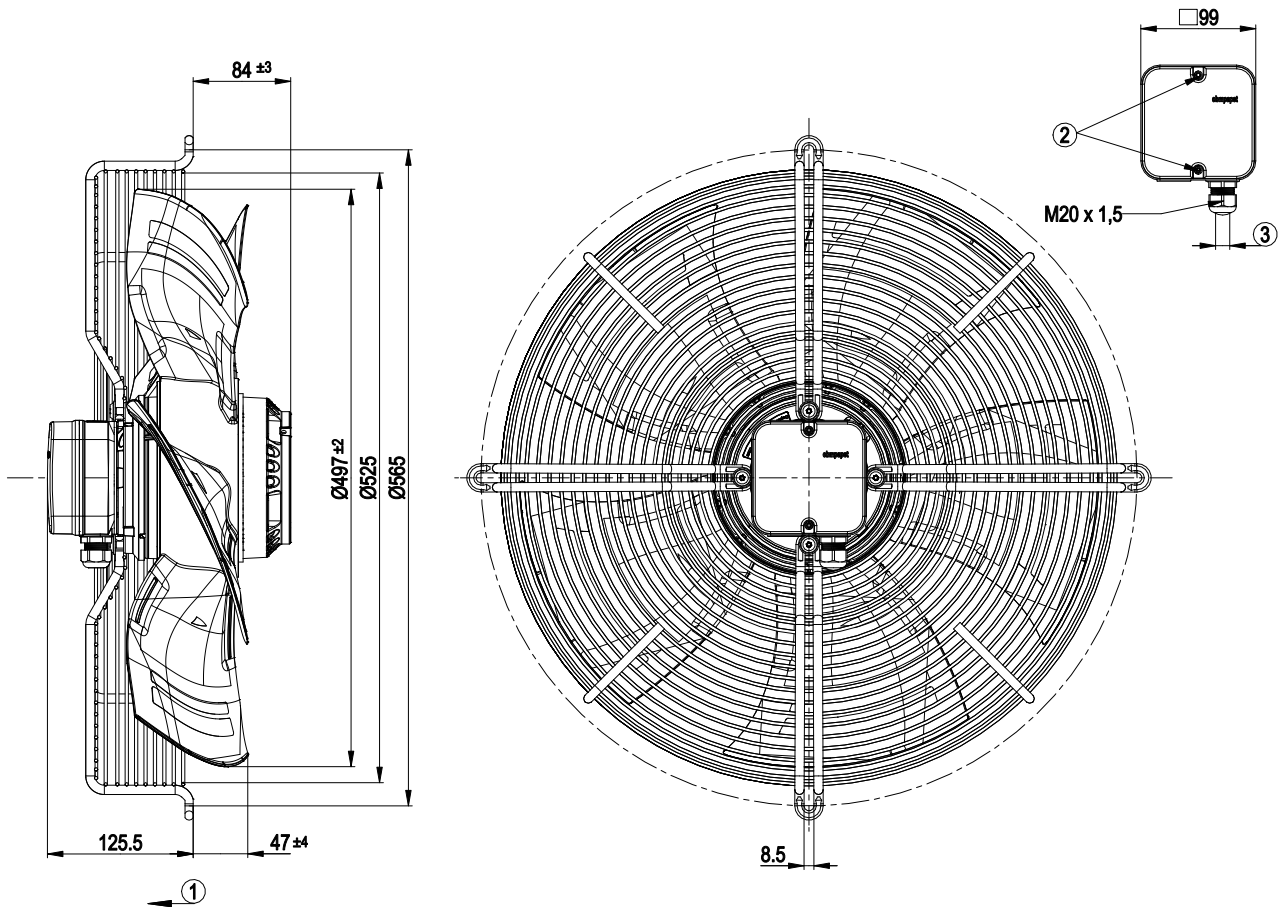

All measures have the unit mm.

1	Direction of air flow "V"
2	Tightening torque $0.8 \pm 0.15$ Nm
3	Cable diameter: min. 6 mm, max. 12 mm, tightening torque: $2.0 \pm 0.3$ Nm

## 3.2 Nominal data

<b>Motor</b>	M4E110-GF	
<b>Phase</b>	1~	1~
<b>Nominal voltage / VAC</b>	230	230
<b>Frequency / Hz</b>	50	60
<b>Type of data definition</b>	ml	ml
<b>Valid for approval / standard</b>	CE	CE
<b>Speed / min<sup>-1</sup></b>	1300	1400
<b>Power input / W</b>	680	880
<b>Current draw / A</b>	3.0	3.88
<b>Motor capacitor / µF</b>	12	12
<b>Capacitor voltage / VDB</b>	450	450
<b>Max. back pressure / Pa</b>	150	100
<b>Min. ambient temperature / °C</b>	-40	-40
<b>Max. ambient temperature / °C</b>	65	40
<b>Max. safe operating speed / min<sup>-1</sup></b>	1920 @ 55 °C	1920 @ 55 °C

ml = Max. load · me = Max. efficiency · fa = Running at free air  
cs = Customer specs · cu = Customer unit

Subject to alterations

## 3.3 Data according to ErP directive

<b>Measurement category</b>	A
<b>Efficiency category</b>	Static
<b>Variable speed drive</b>	No
<b>Specific ratio*</b>	1.00

\* Specific ratio =  $1 + p_{fs} / 100\,000\text{ Pa}$

	Actual	Request 2013	Request 2015
<b>Overall efficiency <math>\eta_{es}</math> / %</b>	32.5	28.5	32.5
<b>Efficiency grade N</b>	40	36	40
<b>Power input <math>P_e</math> / kW</b>	0.65		
<b>Air flow <math>q_v</math> / m<sup>3</sup>/h</b>	5765		
<b>Pressure increase total <math>p_{sf}</math> / Pa</b>	129		
<b>Speed <math>n</math> / min<sup>-1</sup></b>	1315		

Data definition with optimum efficiency.

The ErP data is determined using a motor-impeller combination in a standardised measurement configuration.

## 3.4 Technical features

<b>Size</b>	500 mm
<b>Surface of rotor</b>	Coated in black
<b>Material of terminal box</b>	PC/ABS plastic, black
<b>Material of blades</b>	Press-fitted sheet steel blank, sprayed with PP plastic
<b>Material of guard grille</b>	Steel, phosphated and coated in black plastic
<b>Number of blades</b>	5
<b>Direction of air flow</b>	"V"
<b>Direction of rotation</b>	Counter-clockwise, seen on rotor
<b>Type of protection</b>	IP 54
<b>Insulation class</b>	"F"
<b>Humidity class</b>	F4-1

<b>Mounting position</b>	Shaft horizontal or rotor on bottom; rotor on top on request
<b>Condensate discharge holes</b>	Rotor-side
<b>Operation mode</b>	S1
<b>Motor bearing</b>	Ball bearing
<b>Touch current acc. IEC 60990 (measuring network Fig. 4, TN system)</b>	≤ 3.5 mA
<b>Electrical leads</b>	Via terminal box, integrated capacitor connected via terminal box
<b>Motor protection</b>	Thermal overload protector (TOP) brought out
<b>Cable exit</b>	Axial
<b>Protection class</b>	I (if protective earth is connected by customer)
<b>Motor capacitor according to EN 60252-1 in safety protection class</b>	P0/S0
<b>Product conforming to standard</b>	EN 61800-5-1; CE
<b>Approval</b>	CSA C22.2 Nr.100; EAC; VDE; CCC; UL 1004-1



For cyclic speed loads, note that the rotating parts of the device are designed for maximum one million load cycles. If you have specific questions, contact ebm-papst for support.

## 3.5 Mounting data

⇒ Secure the mounting screws against accidentally coming loose (e.g. by using self-locking screws).

<b>Strength class for mounting screws</b>	8.8
---	-----

You can obtain additional mounting data from the product drawing if necessary.

## 3.6 Transport and storage conditions

⇒ Use the device in accordance with its protection type.

<b>Max. permissible ambient motor temp. (transp./ storage)</b>	+ 80 °C
<b>Min. permissible ambient motor temp. (transp./storage)</b>	- 40 °C

## 4. CONNECTION AND START-UP

### 4.1 Connecting the mechanical system



#### CAUTION

**Cutting and crushing hazard when removing the fan from the packaging**



→ Carefully remove the device from its packaging, only touching the guard grille. Make sure to avoid any shock.

→ Wear safety shoes and cut-resistant safety gloves.

⇒ Check the device for transport damage. Damaged devices must no longer be installed.

⇒ Install the undamaged device according to your application.

⇒ Do not make any modifications, additions or renovations to the device. Replacing the terminal box is not permitted.



#### NOTE

**Motor capacitor**

→ The product is equipped with a motor capacitor with safety protection class P0/S0 according to EN 60252-1. Take this into consideration when fitting it to the end product on the basis of applicable regulations.

### 4.2 Connecting the electrical system



#### DANGER

**Electric voltage on the device**

Electric shock

→ Always install a protective earth first.

→ Check the protective earth.



#### DANGER

**Incorrect insulation**

Risk of fatal injury from electric shock

→ Use only cables that meet the specified installation requirements for voltage, current, insulation material, load etc.

→ Route cables such that they cannot be touched by any rotating parts.



#### DANGER

**Electrical load (>50 µC) between mains wire and protective earth connection after switching of the supply when switching multiple devices in parallel.**

Electric shock, risk of injury

→ Make sure that sufficient protection against accidental contact is provided.

Before working on the electrical connection, the connections to the mains supply and PE must be shorted.

#### CAUTION

**Electrical voltage**

The fan is a built-in component and features no electrically isolating switch.

→ Only connect the fan to circuits that can be switched off with an all-pole separating switch.

→ When working on the fan, you must switch off the installation/machine in which the fan is installed and secure it from being switched on again.

#### NOTE

**Water penetration into leads or wires**

Water enters at the cable end on the customers side and can damage the device.

→ Make sure that the cable end is connected in a dry environment.



Connect the device only to circuits that can be switched off using an all-pole disconnecting switch.

#### 4.2.1 Prerequisites

⇒ Check whether the data on the type plate agree with the connection data and the data of the operating capacitor.

⇒ Before connecting the device, ensure that the supply voltage matches the operating voltage of the device.

⇒ Only use cables designed for current according to the type plate. For determining the cross-section, follow the basic principles in accordance with EN 61800-5-1. The protective earth must have a cross-section equal to or greater than the outer conductor cross-section.

We recommend the use of 105°C cables. Ensure that the minimum cable cross-section is at least AWG26/0.13 mm<sup>2</sup>.

#### Earth wire contact resistance to EN 61800-5-1

Compliance with the impedance specifications to EN 61800-5-1 for the protective earth circuit must be verified in the end application.

Depending on the installation situation, it may be necessary to install an additional protective earthing conductor via the additional protective earth connection point available on the device.

The protective earth connection point is located on the housing and has a protective earth symbol and a bore hole.

#### 4.2.2 Residual current operated device



Only pulse-current sensitive and/or universal RCD protective devices (Type A or B) are permitted. Like frequency inverters, RCD protective devices cannot provide personal safety while operating the device.

#### 4.2.3 Voltage control



With open loop speed control using transformers or electronic voltage regulators (e.g. phase angle control), excessive current may occur.

In addition, noises can occur with phase angle control depending on the mounting situation.

#### 4.2.4 Frequency inverter

Please use a frequency converter only after consultation with ebm-papst. When a frequency converter is used for speed adjustment, the maximum safe operating speed (see 3.2 Nominal data) may not be exceeded.



For operation with frequency converters, fit sinusoidal filters that work on all poles (phase-phase and phase-earth) between the frequency converter and the motor.

During operation with frequency converters, an all-pole sine filter protects the motor against high-voltage transients that can destroy the winding insulation system, and against harmful bearing currents.

Heating of the motor due to use of a frequency converter must be checked in the application by the customer.

### 4.3 Connection in terminal box

#### 4.3.1 Preparing connection lines for the connection

Strip the cable just enough so that the screwed cable gland is tight and the terminals are relieved of strain. Tightening torque, see chapter 3.1 Product drawing.

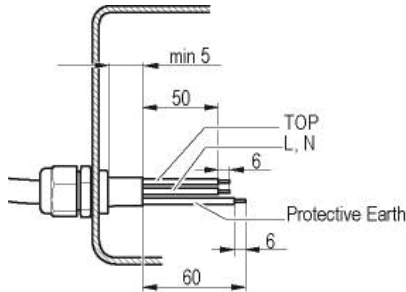

#### 4.3.2 Connecting cables with terminals

- ⇒ Remove the cap from the screwed cable gland.
  - Remove the cap only in those places where cables are inserted.
  - ⇒ Insert the line(s) (not included in the standard scope of delivery) into the terminal box.
  - ⇒ First connect the "PE" (protective earth) connection.
  - ⇒ Connect the lines to the corresponding terminals.
  - ⇒ Connect the thermal overload protector (TOP).
- Use a screwdriver to do so.  
During the connection work, ensure that no cables splice off.  
The terminal strip is equipped with a penetration prevention device.
- ⇒ Insert the strands until they meet resistance.
  - ⇒ Seal the terminal box.

#### 4.3.3 Cable routing

No water may penetrate along the cable in the direction of the cable gland.

##### Fans installed lying flat

Make sure that the cable is routed in the form of a loop (water trap).

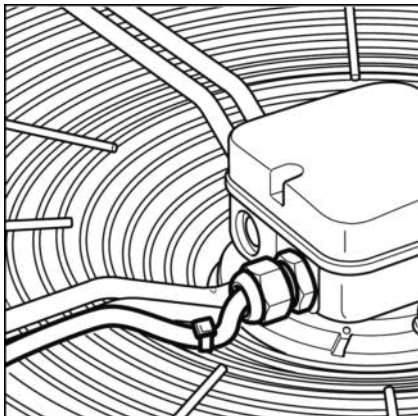

Fig. 2: Fan installed lying flat, cable routed as a water trap.

##### Fans installed in upright position

When routing the cable, ensure that the screwed cable glands are arranged at the bottom. The cables must always be routed downwards.

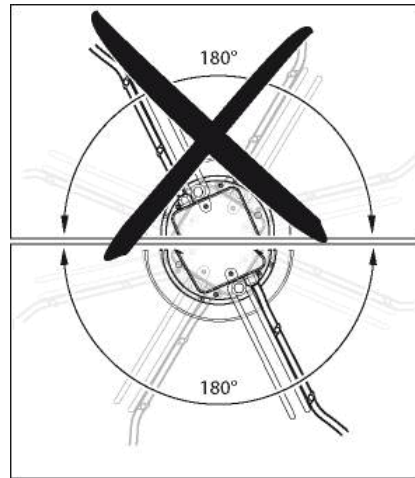

Fig. 3: Cable routing for fans installed upright.

#### 4.3.4 Motor protection

##### CAUTION

##### Voltage

The device is a built-in component with no isolating switch.

- Connect the device to a suitable tripping device.
- Only connect the device to circuits which can be de-energised with an all-pole disconnection switch.
- When working on the device, the system/machine in which the device is installed must be secured so as to prevent it from being switched back on.

##### NOTE

##### Lack of motor protection

Without motor protection, the motor can overheat and suffer damage.

- Connect up the thermal overload protector installed in the coil.

The motors are equipped with thermal overload protectors to protect the devices.

Check to make sure that the thermal overload protector is correctly connected before each operation.

Failure to connect up the thermal overload protector correctly will invalidate your warranty claim.

## 4.4 Connection screen

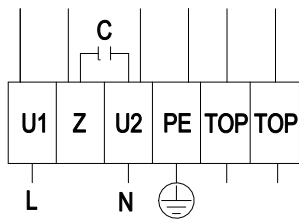

<b>L</b>	= U1 = blue
<b>Z</b>	brown
<b>N</b>	= U2 = black
<b>PE</b>	green / yellow
<b>TOP</b>	grey



#### 4.5 Open additional screwed cable glands

You have the ability to break a second cable gland opening through on the terminal box.

##### WARNING

**In event of a fault, the screwed cable gland is under electrical voltage**

Electric shock

→ Do not use metal cable glands for plastic terminal boxes.

- ⇒ Screw the cable gland into the pre-cut thread using a screwdriver. When doing so, note the tightening torques, see chapter 3.1 Product drawing.
- ⇒ Remove the plastic tab that falls off when the wire is pressed through into the terminal box.

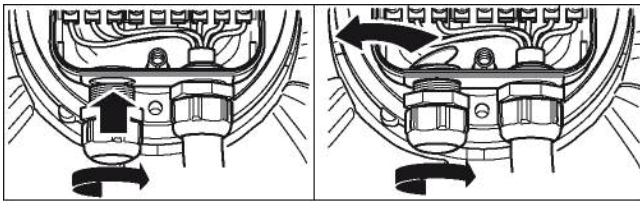

Fig. 4: Screwed cable gland opening

#### 4.6 Checking the connections

- ⇒ Make sure that the power is off (all phases).
- ⇒ Secure it from being switched on again.
- ⇒ Check the correct fit of the connection lines.
- ⇒ Screw the terminal box cover closed again. Terminal box tightening torque, see chapter 3.1 Product drawing.
- ⇒ Make sure that the terminal box is correctly closed and sealed and that all screws and screwed cable glands are properly tightened.

#### 4.7 Switch on device

The device is not to be switched on until it has been installed properly and in accordance with its intended use, including the required protective devices and professional electrical connection. This also applies to devices which have already been equipped with plugs and terminals or similar connectors by the customer.



##### WARNING

**Hot motor housing**

Fire hazard

→ Ensure that no combustible or flammable materials are located close to the fan.

- ⇒ Inspect the device for visible external damage and the proper function of the protective features before switching it on.
- ⇒ Check the air flow paths of the fan for foreign objects and remove any that are found.
- ⇒ Apply the nominal voltage to the voltage supply.

#### 4.8 Switching off the device

- ⇒ Disconnect the device from the supply voltage at the main switch for the supply line.
- ⇒ When disconnecting, be sure to disconnect the earth wire connection last.

## 5. MAINTENANCE, MALFUNCTIONS, POSSIBLE CAUSES AND REMEDIES

Do not perform any repairs on your device. Return the device to ebmpapst for repair or replacement.

### WARNING

**Terminals and connections have voltage even with a unit that is shut off**

Electric shock

→ Wait five minutes after disconnecting the voltage at all poles before opening the device.

### CAUTION

**Electrical load on the capacitor after device is switched off**

Electric shock, risk of injury

→ Discharge the capacitors before working on the device.

### CAUTION

**The motor restarts automatically when operating voltage is applied, e.g. after a power failure.**

Danger of injury

- Keep out of the danger zone of the device.
- When working on the device, switch off the mains supply voltage and secure the latter from being switched on again.
- Wait until the device stops.
- Insert the brought-out thermal overload protector into the control circuit so that the cooled off motor does not switch on independently after a fault.



If the device remains out of use for some time, e.g. when in storage, we recommend switching the device on for at least two hours to allow any condensate to evaporate and to move the bearings.

Malfunction/error	Possible cause	Possible remedy
<b>Impeller running roughly</b>	Imbalance in rotating parts	Clean the device; if imbalance is still evident after cleaning, replace the device. If you have attached any weight clips during cleaning, make sure to remove them afterwards.
<b>Motor does not turn</b>	Mechanical blockage	Switch off, de-energise, and remove mechanical blockage.
	Mains supply voltage faulty	Check mains supply voltage, restore power supply.
	Faulty connection	De-energise, correct connection, see connection diagram.
	Thermal overload protector responded	Allow motor to cool off, locate and rectify cause of error, if necessary cancel restart lock-out

	Unacceptable operating point	Check operating point
<b>Overtemperature of motor</b>	Ambient temperature too high	Lower ambient temperature if possible
	Insufficient cooling	Improve cooling



If you have any other problems, contact ebm-papst.

### 5.1 Cleaning

#### NOTE

**Damage to the device during cleaning.**

Malfunction possible

- Do not clean the device using a water jet or high-pressure washer.
- Do not use any cleaners containing acids, bases or solvents.
- Do not use any pointed or sharp-edged objects to clean.

### 5.2 Safety test

What has to be tested?	How to test?	Frequency	Which measure?
Check the protective casing against accidental contact for damage and to ensure that it is intact	Visual inspection	At least every 6 months	Repair or replacement of the device
Check the device for damage to blades and housing	Visual inspection	At least every 6 months	Replacement of the device
Mounting the connection lines	Visual inspection	At least every 6 months	Fasten
Mounting of protective earth connection	Visual inspection	At least every 6 months	Fasten
Check the insulation of the wires for damage	Visual inspection	At least every 6 months	Replace wires
Tightness of screwed cable gland	Visual inspection	At least every 6 months	Retighten, replace if damaged
Condensate discharge holes for clogging, as necessary	Visual inspection	At least every 6 months	Open bore holes
Weld seams for crack formation	Visual inspection	At least every 6 months	Replace device