



SHP
Level Transducer Probes

SVP

INTRODUCTION

Due to the increasing cost of refrigerants and to governmental regulations concerning the escape, leakage, and replenishment of refrigerants, more accurate and sophisticated methods are needed to track and conserve refrigerant usage. The S series level transducer probes are specifically designed to be inserted directly into refrigerant receivers. They facilitate the continuous, accurate measurement of refrigerant liquid levels. The information provided by these probes can help in refrigerant loss detection and refrigerant inventory measurements. When used in conjunction with alarms, they can warn of excessive or insufficient refrigerant quantity. These probes can also be valuable troubleshooting tools, helping to quickly return a refrigeration system to normal operation after service. They are available with standard NPT or optional Rotalock connections.

KEY FEATURES

- Replaceable solid-state electronics
- No moving parts to break, jam, or fail
- Can provide measurements along the entire length of the probe
- Proven, nonoptic design
- 0-5, 1-6 volt DC signal output*
- Standard 3/4" NPT fitting (SHP, SVP), optional 1/4" Rotalock connection (SHPR, SVPR)
- Custom lengths available
- Watertight NEMA 4 (IP65) enclosure
- Suitable for R22, R134a, and other compatible refrigerants
- Choice of connections: NPT or Rotalock

**Specifications, Applications,
Service Instructions & Parts**

**S SERIES
REFRIGERANT LEVEL
TRANSDUCER PROBES**

**0-5 or 1-6 Volt DC Output
for Vertical or
Horizontal Receivers**

TYPICAL APPLICATIONS

VERTICAL RECEIVER

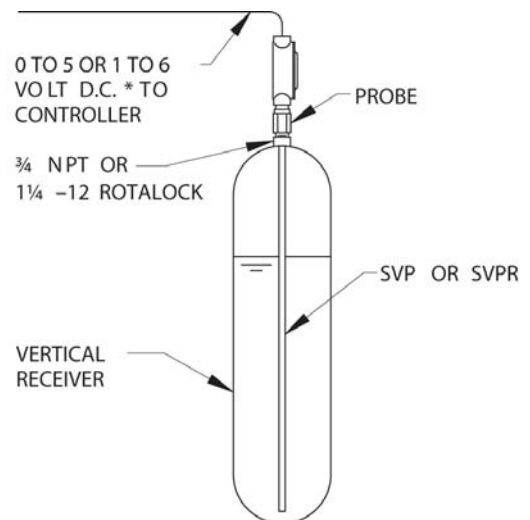

HORIZONTAL RECEIVER

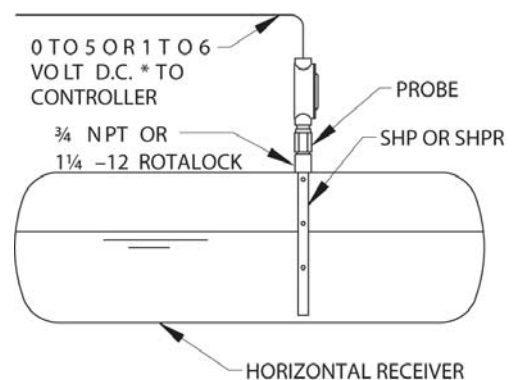

*0-10 volt DC output will be available soon

MATERIAL SPECIFICATIONS

ELECTRICAL

Signal Output: 0–5 or 1–6 volt DC (0–10 volt DC available soon) proportional to liquid level

Maximum Load: 10K ohms

Power Consumption: 1 VA maximum

Supply Voltage: 11 to 36 volt DC

Ambient Temperature Range: –20°F to +125°F
(–28.9°C to +52°C)

Enclosure: NEMA 4, watertight (IP65)

Linearity: Typically $\pm 0.5\%$ of actual

MECHANICAL

Safe Working Pressure: 400 psig (27 bar); 500 psig (34 bar) available. Contact the factory.

Refrigerant Temperature: 50°F to 150°F (10°C to 65°C); Heavy-duty construction available for other temperatures.

Probe: Stainless steel, Teflon encased

Shielding Tube (SHP & SHPV models only):
Stainless steel

Fitting: Steel, zinc chromate plated

Connection Style: $\frac{3}{4}$ " NPT or $1\frac{1}{4}$ "–12 Rotalock

APPLICATION

Horizontal Receivers: from 6" to 24" (152 mm to 610 mm) diameter

Vertical Receivers: from 12" to 20" (304 mm to 508 mm) diameter
(other diameters need special engineering)

ADVANTAGES

These level transducer probes are normally supplied factory precalibrated and tested. There are no moving parts to break, jam, or fail. The probe-to-receiver connection is a simple $\frac{3}{4}$ " NPT or $1\frac{1}{4}$ "–12 Rotalock. These probes provide a 0–5 or 1–6 volt DC output proportional to liquid level. The type of signal output is selected through a simple jumper setting. Both signals are commonly used for supermarket refrigeration rack system controllers, PLCs, and other accessories for various purposes. The signal output is conditioned to ignore normal turbulence inside receiver to provide a steady, accurate indication of level.

These probes permit easy and precise set up of: high level alarm/cutout, low level alarm/cutout, level monitoring, and refrigerant inventory calculation. If the signal is input to a PLC or rack system controller with modem capabilities, it can be remotely accessed for troubleshooting, refrigerant inventory control, or other purposes.

Installation of probes into a separate level column is not normally necessary. If desired, horizontal receiver probes (SHP, SHPR models) can usually be directly inserted into level columns without modification. For vertical receiver probes (SVP, SVPR models), special construction or calibration may be required. Contact the factory. Electronics can be replaced without opening the refrigeration system.

Heavy-duty construction (S prefix) is available for nonstandard applications where the ambient or refrigerant temperature range is exceeded, probe is inserted into cold evaporators or accumulators, or for outdoor use. This version includes an extended probe body neck, special electronic temperature compensation, and epoxy-resin-encapsulated electronics for extra moisture protection.

INSTALLATION

To select the proper probe length, the receiver inside height and fitting length must be known. See the diagram below. Subtract 1.06" or 27 mm (for typical engagement plus the probe minimum clearance to the receiver bottom) from the "F" dimension. The result is the maximum possible insertion length of the probe. The actual probe insertion length may be less, perhaps down to the next standard insertion length, provided it is long enough to measure the lowest desired receiver level. The minimum clearance is suggested to avoid possible damage to the probe by running it into the bottom of the receiver. The probe insertion length cannot be changed in the field.

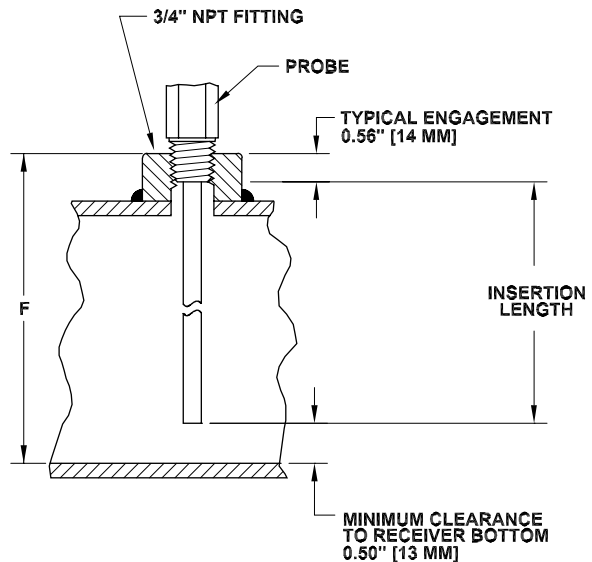

Locate the fitting away from the liquid inlet of the receiver to avoid splashing the probe with incoming refrigerant. Also, avoid possible probe interference with the dip tube or other internal parts. Adequate clearance above the $\frac{3}{4}$ " FPT fitting on the receiver should be provided for installation and removal of the probe without bending it.

Carefully remove the probe from the carton. Use proper sealant on the probe-to-receiver connection. For SVP, electrical contact is required via the NPT threaded fitting. Do not use Teflon tape. Insert the probe into the NPT opening on the receiver. Tighten the probe on the hex. Do not grip the probe housing. Pressurize the receiver and test for leaks.

ELECTRICAL

These level transducer probes are low voltage, three wire devices. The control loop wiring size should be at least 20 AWG (0.5 mm²) and limited to 100 ft. (30 m) in length. For best electrical noise protection, do not run the control loop wiring with, or near, the power wiring. See page 3 for a typical wiring diagram. If erratic output occurs, verify proper operation by placing the probe on a separate power supply. Then, disconnect the output signal from the computer and measure the output using a voltmeter across terminals 2 and 3 **at the probe**. The power supply must be properly grounded to avoid potential ground loops resulting in erratic signal output.

INSTALLATION DIMENSIONS

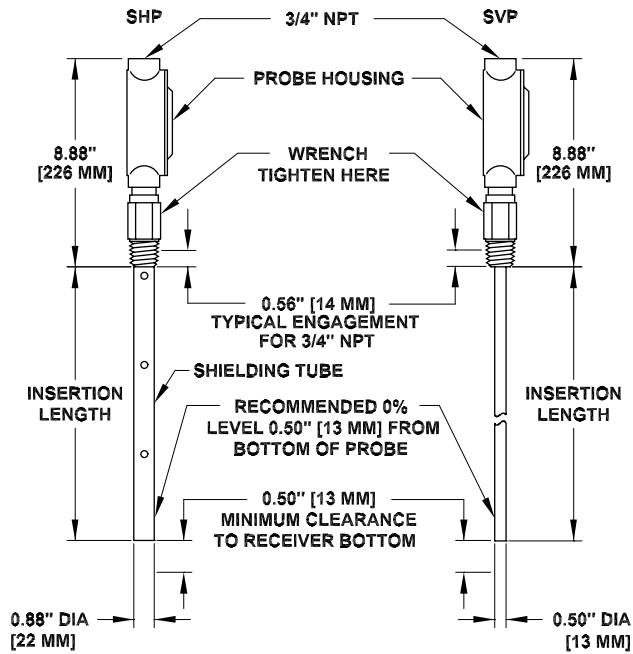

| FOR HORIZONTAL RECEIVERS* | | | |
|---------------------------|------------------|----------|------------------|
| CAT. NO. | INSERTION LENGTH | CAT. NO. | INSERTION LENGTH |
| SHP06 | 6" (152 mm) | SHPR06 | 7" (179 mm) |
| SHP08 | 8" (203 mm) | SHPR08 | 9" (229 mm) |
| SHP12 | 12" (305 mm) | SHPR12 | 13" (330 mm) |
| SHP16 | 15.3" (387 mm) | SHPR16 | 16.25" (413 mm) |
| SHP20 | 19.2" (487 mm) | SHPR20 | 20.25" (514 mm) |
| SHP24 | 23.1" (586 mm) | SHPR24 | 24.25" (616 mm) |

| FOR VERTICAL RECEIVERS* | | | |
|-------------------------|------------------|----------|------------------|
| CAT. NO. | INSERTION LENGTH | CAT. NO. | INSERTION LENGTH |
| SVP36 | 36" (914 mm) | SVPR36 | 37" (940 mm) |
| SVP48 | 48" (1219 mm) | SVPR48 | 49" (1245 mm) |
| SVP54 | 54" (1372 mm) | SVPR54 | 55" (1397 mm) |
| SVP60 | 60" (1524 mm) | SVPR60 | 61" (1550 mm) |

*Horizontal Receiver Probes (SHP or SHPR) should also be used in vertical receivers that are shorter than 23.1" (587 mm) insertion, narrower than 12" (304 mm) diameter, or wider than 20" (508 mm) diameter.

TYPICAL WIRING DIAGRAM

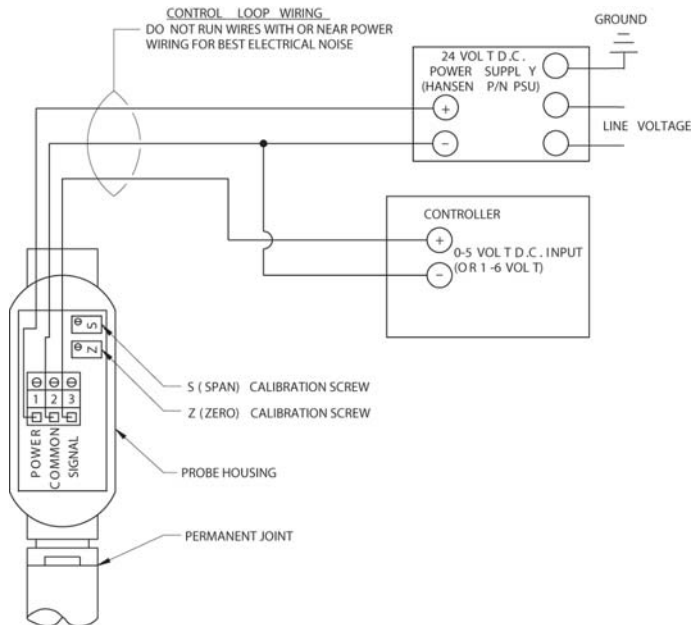

Important: To protect electronics from moisture, dirt, etc., seal the 3/4" NPT electrical opening on top of the probe housing with a watertight cable connector or seal the wires inside a field-installed conduit fitting with silicone sealant.

RECALIBRATION INSTRUCTIONS

These transducer probes are accurately factory precalibrated for receivers with the specified refrigerant. SHP(R) probes should not require any field calibration unless the refrigerant is different than specified on the probe housing. However, it is the responsibility of the installer to ensure proper calibration. SVP(R) probes are factory calibrated

for a 16" diameter vertical receiver and generally only require recalibration for other receiver diameters or refrigerants. Unless otherwise requested, probes are calibrated for R22/R404A. This standard calibration is also suitable (within 5%) for R134a, R507, R23, and R410A. For greatest accuracy, the probes should be recalibrated after the system has operated for a time and once the system operation, refrigerant chemistry, and level probe have reached equilibrium.

The transducer probe recalibration can be performed with the jumper in either the 0-5 or 1-6 position. The following procedure assumes the jumper is in the 0-5 position. If the recalibration is done with the jumper in the 1-6, add 1 volt DC to the voltage measurements specified below.

Monitor the output voltage using a voltmeter installed in parallel with the signal and common leads of the control loop (terminals 2 and 3). Lower the refrigerant level in the receiver to a level equal to 0%. The voltmeter reading should be 0.0 volts DC. If not, adjust the Z (ZERO) calibration screw for a reading of 0.0 volts DC.

Raise the liquid level in the receiver to the 50% level. The voltmeter reading should be 2.5 volts DC. If not, adjust the S (SPAN) calibration screw. The recalibration is complete.

To change the signal type, simply move the jumper to the appropriate position. No recalibration or adjustment is required.

CAUTION

These transducer probes are for refrigeration systems only. These instructions and related safety precautions must be completely read and understood before selecting, using, or servicing these probes. Only knowledgeable, trained refrigeration technicians should install, operate, or service these probes. Stated temperature and pressure limits should not be exceeded. Probes should not be removed from the receiver unless the system has been evacuated to zero pressure. Escaping refrigerant can cause injury, especially to the eyes and lungs.

WARNING: As with all electronic and mechanical components, there is a limited product life expectancy. An expected life of seven to ten years is typical. This should be understood as only a suggested replacement time period. Actual condition and performance of electronics due to ambient conditions, quality of electrical current, voltage, etc., may necessitate a different replacement schedule. Regardless, probes should be inspected at least once a year to ensure their safe and continuous service. See also Safety Precautions in the current List Price Bulletin and the Safety Precautions Sheet supplied with this product.

TROUBLESHOOTING

The S series probes are simple, solid-state devices. Very few things can go wrong with these probes. However, if a problem arises, these guidelines should be followed when troubleshooting the probe.

Make sure that the actual conditions match the calibration conditions. The refrigerant that the probe is calibrated for is stamped on the probe housing. The factory calibration is only good for this refrigerant. Excessive oil or water, or a different refrigerant, in the receiver will adversely affect the calibration.

The factory-set SPAN (S) adjustment rarely needs to be changed in the field. Change this setting only as a last resort or when advised to do so by the factory.

If the computer indicates that the probe is not functioning properly, first connect a voltmeter to the probe and verify correct voltage, as explained on page 2. Experience and field testing have shown that the problem usually lies in the computer or computer/probe interface, and not with the probe itself.

It is very important to prevent moisture from entering the probe housing at all times. Take steps to ensure that the internal electronics stay dry during storage, installation, and operation. Moisture inside the probe housing can irreversibly damage the probe electronics.

ORDERING INFORMATION, LEVEL TRANSDUCER PROBES

| FOR HORIZONTAL RECEIVERS | | | |
|--------------------------|------------------|----------|------------------|
| CAT. NO. | INSERTION LENGTH | CAT. NO. | INSERTION LENGTH |
| SHPR06 | 7" (179 mm) | SHP06 | 6" (152 mm) |
| SHPR08 | 9" (229 mm) | SHP08 | 8" (203 mm) |
| SHPR12 | 13" (330 mm) | SHP12 | 12" (305 mm) |
| SHPR16 | 16.25" (413 mm) | SHP16 | 15.3" (387 mm) |
| SHPR20 | 20.25" (514 mm) | SHP20 | 19.2" (487 mm) |
| SHPR24 | 24.25" (616 mm) | SHP24 | 23.1" (586 mm) |
| SHPRXX | Custom Length | SHPXX | Custom Length |

Horizontal receiver probes (SHP, SHPR [Rotalock]) should also be used in short, narrow or wide vertical receivers.

| FOR VERTICAL RECEIVERS | | | |
|------------------------|------------------|----------|------------------|
| CAT. NO. | INSERTION LENGTH | CAT. NO. | INSERTION LENGTH |
| SVPR36 | 37" (940 MM) | SVP36 | 36" (914 mm) |
| SVPR48 | 49" (1245 MM) | SVP48 | 48" (1219 mm) |
| SVPR54 | 55" (1397 MM) | SVP54 | 54" (1372 mm) |
| SVPR60 | 61" (1550 MM) | SVP60 | 60" (1524 mm) |
| SVPRXX | Custom Length | SVPXX | Custom Length |

Vertical receiver probes (SVP, SVPR [Rotalock]) should be used in vertical receivers 12" to 20" (304 mm to 508 mm) in diameter. Other diameters require special engineering.

TO ORDER

Specify the catalog number, refrigerant, and factory calibration (0–5 volt or 1–6 volt). Custom insertion length probes and heavy-duty construction options are available at an additional cost, but may take longer to manufacture and are nonreturnable. For heavy-duty construction, add S prefix. For example, SSHP20 is a heavy-duty, 20", horizontal receiver probe.

For industrial refrigeration applications which may require special electronic "noise" isolation or greater temperature range, cable length, control units, etc., contact Hansen for information. Available are the Vari-Level Adjustable Level Controls with control unit and level probe, Techni-Level Transducer Probes with direct 4–20 mA output, and other products.

WARRANTY

Hansen electronics are guaranteed against defective materials or workmanship for 90 days F.O.B. our factory. All other components are guaranteed for one year F.O.B. our factory. No consequential damages or field labor is included.

HANSEN TECHNOLOGIES CORPORATION

6827 High Grove Boulevard
Burr Ridge, Illinois 60527 USA
Tel: (630) 325-1565 Fax: (630) 325-1572
Toll: (800) 426-7368 <http://www.hantech.com>

© 2004 Hansen Technologies Corporation