

# DELTA-P II Differential oil pressure sensor

## DELTA-P II

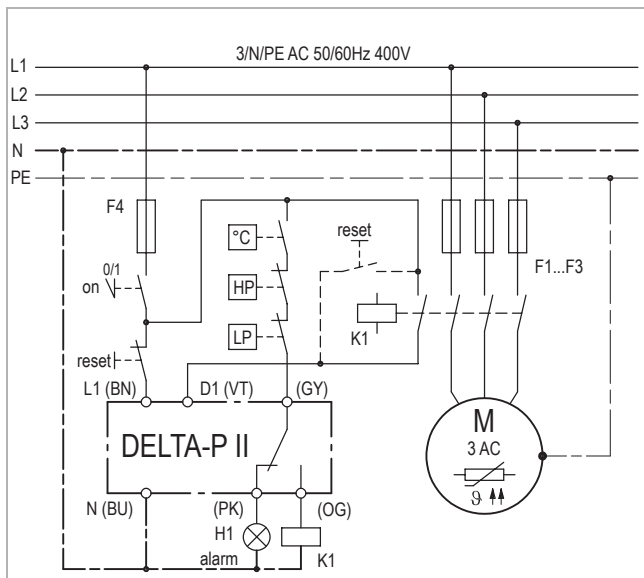

DELTA-P II



Wiring diagram

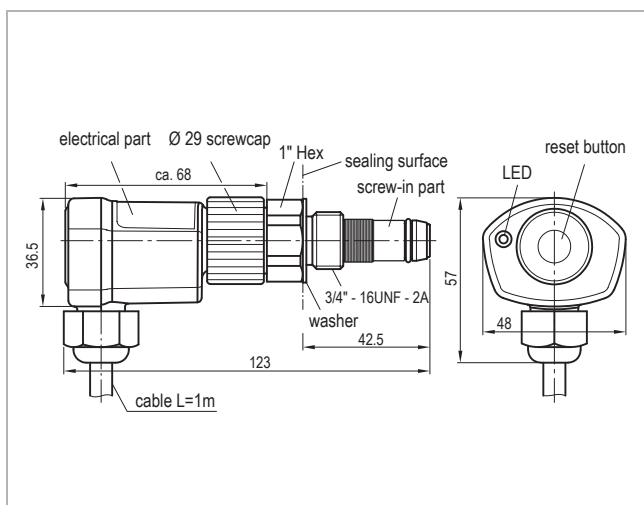

Dimensions in mm

### Application

The DELTA-P II serves to monitor the oil differential pressure of oil pumps in refrigeration compressors. For this a screw-in part that is mounted directly in the pump housing is evaluated for differential pressure measurement. The screw-in part is thereby connected by internal channels with the suction and high pressure side of the pump. Supplementary pipe connections are not needed. The evaluation unit is fastened by a coupling ring in the screw-in part and can be removed without opening the oil/refrigeration circuit.

### Functional description

Once the supply voltage has been switched on, the relay trips after a 3 second delay. With a previously locked switching off of the relay, a reset delay of 120 seconds is started. With the operating recognition signal, which is applied to D1 via an auxiliary contactor of motor contactor, the differential pressure monitoring is activated after the expiration of a starting transition time. A missing differential pressure leads to a locked switch off after 120 seconds; with differential pressure fluctuation appropriately later (time integration). A reset of the relay can be carried out by the built-in button, by activating the operating recognition or by a network reset (see circuit diagram). The monitoring of internal errors is always active. Any faults that occur in any operational phase lead to a locked switch off of the relay after 5 seconds. The potential-free contact can be looped into a safety circuit without an auxiliary relay. An installation check monitors the proper assembly. The built-in LED indicates the actual operating state.

### Flash code of the red LED:

- 10Hz flashing: Internal error
- Voltage supply too low
- Not screwed into screw-in part
- Operating recognition on, but relay off
- 1Hz flashing: Reset delay
- Continuous light: No differential pressure available
- Off: Differential pressure OK, no error

### Installation instructions

**Mounting:** The maximum torque of the screw-in unit is about 75Nm and has to be ensured by a ring spanner or a socket key. After mounting, check the seal. Follow the rules when working on refrigeration systems!

Insert the evaluation unit in the screw-in unit and screw tight by hand with the coupling ring (torque about 10Nm). Make sure that the cable outlet points down. The electrical connection needs to be carried out according to the proposal in the wiring diagram.



The mounting, maintenance and operation are to be carried out by an electrician. The valid European and national standards for connecting electrical equipment and cooling installations have to be observed. Connected sensors and connection lines that extend from the terminal box have to feature at least a basic insulation.

### Order data

DELTA-P II Electrical part	<b>22 S 295</b>
DELTA-P Screw-In part 3/4" - 16UNF - 2A 0.65bar	<b>02 D 445</b>

# DELTA-P II Differential oil pressure sensor

## DELTA-P II

### Technical specifications

#### Screw-in unit

Permitted medium temperature	-30...+90°C
Differential pressure	0.65bar ±0.15bar
Operating pressure	30bar
Housing material	Brass
Connection thread	3/4" – 16UNF – 2A
Weight	About 100g

#### Evaluation unit

Connection:	
- Dual voltage	AC 50/60Hz 115-230V -15...+10%
Connection operating recognition (D1)	AC 50/60Hz 115-230V -15...+10%
Dual voltage	L-potential at connection D1
Permitted ambient temperature	-30...+70°C
Delays:	
- Relay On after applying the supply voltage	3s ±1s
- Relay on after precious locking	120s ±5s
- Starting transition time D1 active	5s ±2s
- Relay off (error)	5s ±2s
- Relay off (diff.-pressure missing)	120s ±5s (time integration)
- Reset by interrupting the supply voltage	About 5s
- Reset by button	About 1s
- Reset by operating recognition (D1)	About 1s
Output relay	AC 240V 2.5A C300
Mechanical service life	Approx. 1 million switching cycles
Protection class acc. to EN 60529	IP54 in built-in status
Connection type	Cable 6xAWG-18 (0.75mm <sup>2</sup> ), L=1m, colour coded
Housing material	PA glass-fibre-reinforced
Mounting	Union nut
Weight	About 160g
Check base	EN 61000-6-2 EN 61000-6-3 EN 61010-1 Overvoltage category II Pollution level 2
Approval	UL File No. E222056