

Integral-Bonnet Needle Valves



O, 1, 18, 20, and 26 Series

- Live-loaded packing system
- Compact design
- Working pressures up to 6000 psig (413 bar)
- Temperatures up to 600°F (315°C)

Features

Stem Designs

- Vee—all series
- Soft-seat—all series
- Regulating—O, 1, and 18 series

Orifice Sizes

- From 0.080 to 0.375 in. (2.0 to 9.5 mm)

Flow Coefficients (C_v)

- From 0.09 to 1.80

Flow Patterns

- Straight, angle, and cross patterns

Panel Mounting

- O, 1, and 18 series

Live-Loaded Packing System

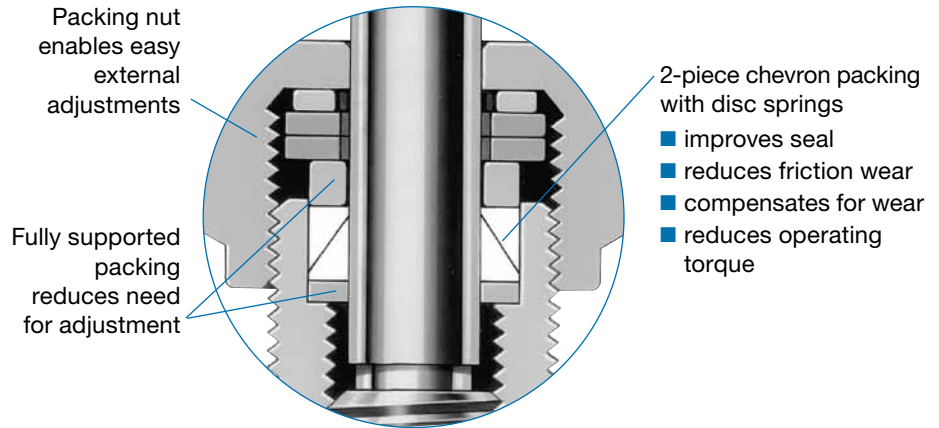

O, 1, and 18 Series

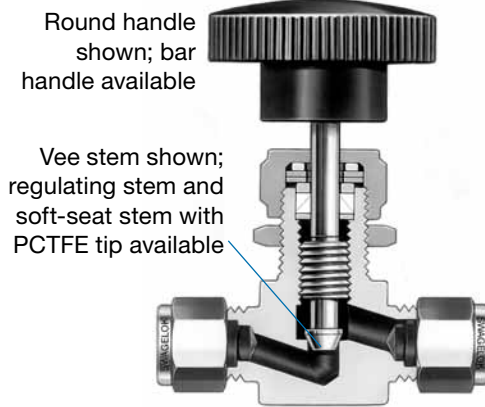

20K Series

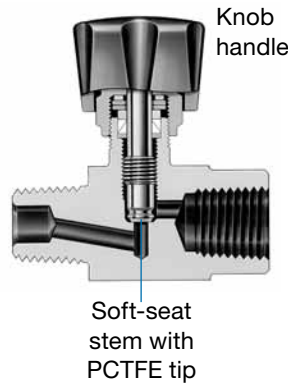

20V and 26 Series

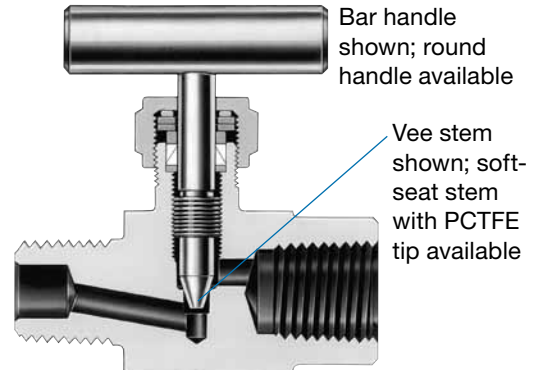

Pressure-Temperature Ratings

Ratings are limited to:

- 200°F (93°C) max with soft-seat stem with PCTFE stem tip.
- 250°F (121°C) max with UHMWPE packing.
- 450°F (232°C) max with PFA packing.
- 600°F (315°C) max with PEEK packing.

To order a valve with soft-seat stem and PCTFE stem tip, see **Ordering Information and Dimensions**, page 4 and 6.

To order a valve with UHMWPE or PEEK packing, see **Options and Accessories**, page 7.

O, 1, and 18 Series

ASME Class	2080	N/A		1500
Material Group	2.2	N/A		3.4
Material Name	316 SS	Brass	Steel	Alloy 400
Temperature, °F (°C)	Working Pressure, psig (bar)			
-65 (-53) to -20 (-28)	5000 (344)	3000 (206)	—	3000 (206)
-20 (-28) to 100 (37)	5000 (344)	3000 (206)	3000 (206)	3000 (206)
200 (93)	4295 (295)	2350 (161)	2730 (188)	2640 (181)
250 (121)	4085 (281)	2200 (151)	2695 (185)	2555 (176)
300 (148)	3875 (266)	2050 (141)	2660 (183)	2470 (170)
350 (176)	3715 (255)	1470 (101)	2615 (180)	2430 (167)
400 (204)	3560 (245)	390 (26)	—	2390 (164)
450 (232)	3435 (236)	—	—	2380 (163)
500 (260)	3310 (228)	—	—	2375 (163)
600 (315)	3130 (215)	—	—	—

20 and 26 Series

ASME Class	2500
Material Group	2.2
Material Name	316 SS
Temperature °F (°C)	Working Pressure psig (bar)
-65 (-53) to 100 (37)	6000 (413)
200 (93)	5160 (355)
250 (121)	4910 (338)
300 (148)	4660 (321)
350 (176)	4470 (307)
400 (204)	4280 (294)
450 (232)	4130 (284)
500 (260)	3980 (274)
600 (315)	3760 (259)

For more information about pressure ratings of valves with tube fitting end connections, see *Swagelok Tubing Data*, MS-01-107.

Materials of Construction

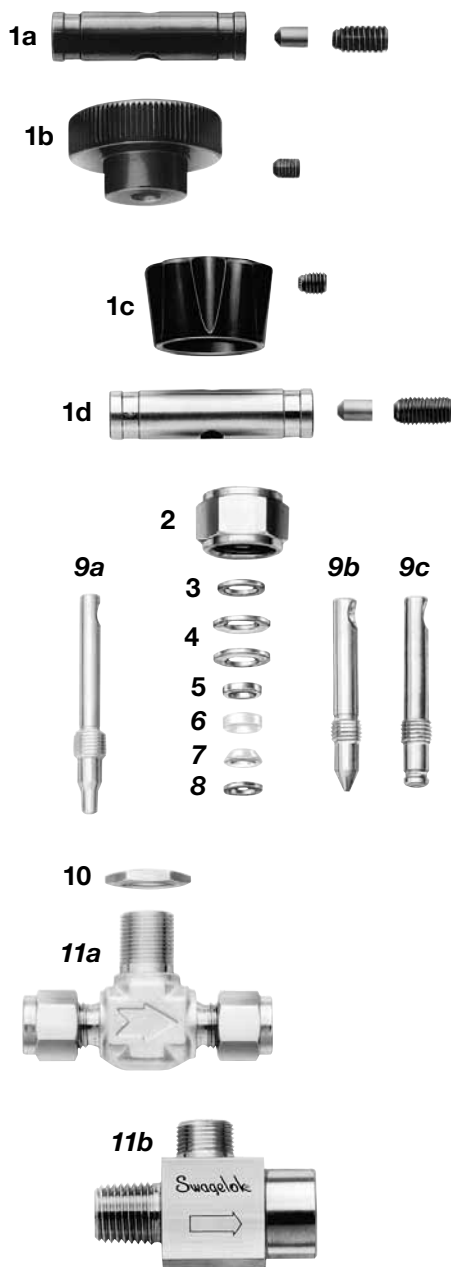

Component	Series	Valve Body Materials			
		Material Grade/ASTM Specification			
		316 SS	Brass	Steel	Alloy 400
1a Bar handle Handle pin Set screw	18	Anodized aluminum 2024/B221 or A209			
		Steel/A108			
		Nickel cadmium-plated steel			
1b Round handle Set screw	O and 1	Phenolic with brass insert			
		Nickel cadmium-plated steel			
1c Knob handle Set screw	20K	Anodized aluminum 7129/B221	—		
		Nickel cadmium-plated steel	—		
1d Bar handle Handle pin, set screw	20V and 26	316 SS/A276	—		
		S17400/A564	—		
2 Packing nut	All	316 SS/A276	Brass 360/B16	12L14/A108	Alloy 400/B164
3 Gland	O, 1, ^① and 20	304 SS/A240, A167			
4 Packing springs	All ^②	S17700/A693			
5 Packing gland	All	316 SS/A240, A276, B783			
6 Upper packing	All	PFA/D3307			
7 Lower packing					
8 Lower gland	All	316 SS/A240			Alloy 400/B127
9a Regulating stem	O, 1, and 18	Chrome-plated ^③ 316 SS/A276	316 SS/A276	Alloy 400/B164	
9b Vee stem	All				
9c Soft-seat stem Stem tip	All				
10 Panel nut	O, 1, and 18	316 SS	Brass 360/B16	316 SS	
11a Body	O, 1, and 18	316 SS/A182	Brass 377/B283	Cadmium-plated 11L17/A108	Alloy 400/B564
11b Body	20 and 26	316 SS/A479	—		
Lubricant	All	Tungsten disulfide- and fluorocarbon-based			

Wetted components listed in *italics*.

Valve series listed with standard handles. For handle options, see **Handles**, page 8.

① 1 series valves with orifice of 0.172 in. (4.4 mm).

② O, 20 and 1 series with orifice of 0.172 (4.4 mm)—2 springs;
18, 26, and 1 series with orifice of 0.250 (6.4 mm)—3 springs.

③ Regulating and vee stem tip and threads; soft-seat stem threads.

Testing

Every integral-bonnet needle valve is factory tested with nitrogen at 1000 psig (69 bar). Seats have a maximum allowable leak rate of 0.1 std cm³/min. Shell testing is performed to a requirement of no detectable leakage with a liquid leak detector.

Cleaning and Packaging

All integral-bonnet needle valves are cleaned and packaged in accordance with Swagelok *Standard Cleaning and Packaging (SC-10)*, MS-06-62. Cleaning and packaging in accordance with Swagelok *Special Cleaning and Packaging (SC-11)*, MS-06-63, to ensure compliance with product cleanliness requirements stated in ASTM G93 Level C are available as an option.

Flow Data at 100°F (37°C)

Flow Coefficient at Turns Open

O and 1 Series

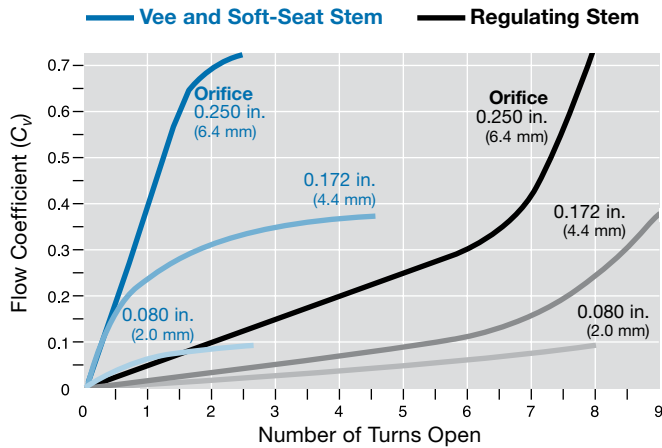

18 Series

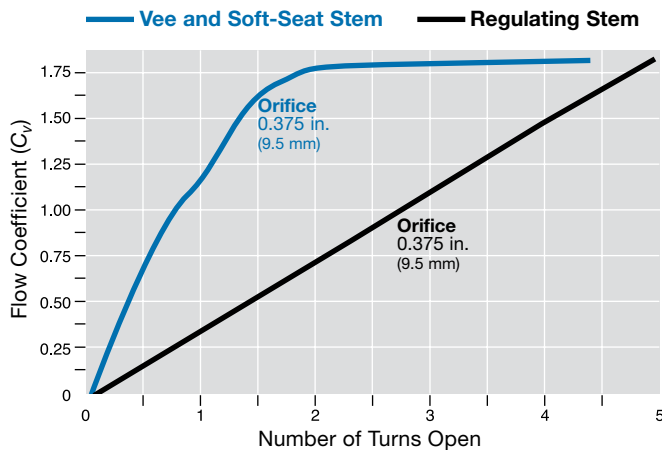

20 and 26 Series

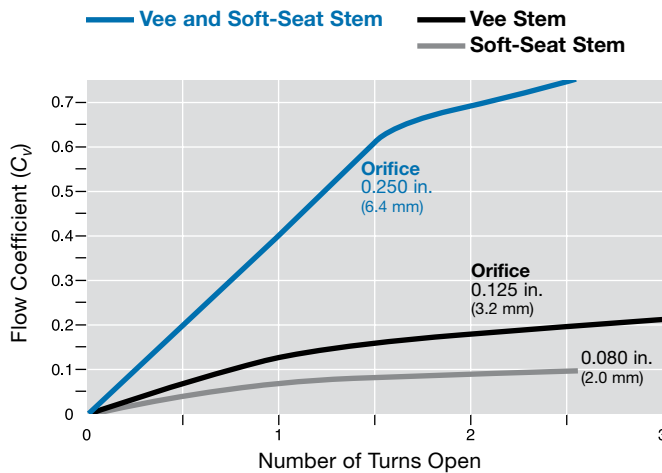

Ordering Information and Dimensions

O, 1, and 18 Series

Dimensions, in inches (millimeters), are for reference only and are subject to change.

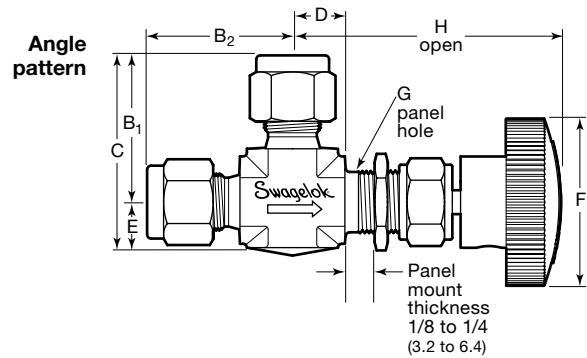
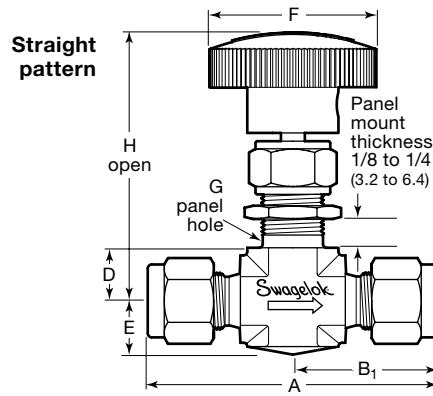

Stainless Steel Valves with Regulating Stems

Select an ordering number.

Alloy 400, Brass, and Steel Valves with Regulating Stems

Replace **SS** in the ordering number with a material designator.

Example: **M-ORS2**

Material	Designator
Alloy 400	M
Brass	B
Steel	S

Vee and Soft-Seal Stems

Replace **R** in the ordering number with **V** for a vee stem or **K** for a soft-seat stem with PCTFE stem tip.

Examples: **SS-OVS2**
SS-OKS2

Angle-Pattern Valves

Add **-A** to the ordering number.

Example: **SS-ORS2-A**

Cross-Pattern Valves

Certain 1 series valves are available with cross-pattern bodies, which provide continuous flow between the side ports and on-off or regulating flow through the bottom port. Shown at right: **SS-1RS4-X**

Contact your authorized Swagelok sales and service representative for more information and additional ordering numbers.



End Connections		C _v	Orifice in. (mm)	Ordering Number	Dimensions, in. (mm)								
Inlet/Outlet	Size				A	B ₁	B ₂	C	D	E	F	G	H
Fractional Swagelok tube fittings	1/8 in.	0.09	0.080 (2.0)	SS-ORS2	1.94 (49.3)	0.98 (24.9)		1.29 (32.8)	0.44 (11.2)	0.31 (7.9)	1.00 (25.4)	0.47 (11.9)	2.28 (57.9)
	1/4 in.	0.37	0.172 (4.4)	SS-1RS4	2.27 (57.6)	1.13 (28.7)		1.51 (38.4)		0.38 (9.7)	1.38 (35.1)	0.53 (13.5)	2.50 (63.5)
	3/8 in.	0.73	0.250 (6.4)	SS-1RS6	2.58 (65.5)	1.29 (32.8)		1.79 (45.5)	0.55 (14.0)	0.50 (12.7)	1.88 (47.8)	0.78 (19.8)	2.97 (75.4)
	1/2 in.			SS-1RS8	2.80 (71.1)	1.40 (35.6)		1.90 (48.3)					
	1/2 in.	1.80	0.375 (9.5)	SS-18RS8	3.80 (96.5)	1.90 (48.3)		2.65 (67.3)	0.75 (19.1)		3.00 (76.2)	1.03 (26.2)	3.91 (99.3)
	3/4 in.			SS-18RS12									
Metric Swagelok tube fittings	3 mm	0.09	0.080 (2.0)	SS-ORS3MM	1.94 (49.3)	0.98 (24.9)		1.29 (32.8)	0.44 (11.2)	0.31 (7.9)	1.00 (25.4)	0.48 (12.2)	2.28 (57.9)
	6 mm	0.37	0.172 (4.4)	SS-1RS6MM	2.27 (57.6)	1.13 (28.7)		1.51 (38.4)		0.38 (9.7)	1.38 (35.1)	0.53 (13.5)	2.50 (63.5)
	8 mm			SS-1RS8MM	2.34 (59.4)	1.17 (29.7)		1.54 (39.1)					
	10 mm	0.73	0.250 (6.4)	SS-1RS10MM	2.60 (66.0)	1.30 (33.0)		1.80 (45.7)	0.55 (14.0)	0.50 (12.7)	1.88 (47.8)	0.78 (19.8)	2.97 (75.4)
	12 mm			SS-1RS12MM	2.80 (71.1)	1.40 (35.6)		1.90 (48.3)					
	12 mm	1.80	0.375 (9.5)	SS-18RS12MM	3.80 (96.5)	1.90 (48.3)		2.65 (67.3)	0.75 (19.1)		3.00 (76.2)	1.03 (26.2)	3.91 (99.3)
	18 mm			SS-18RS18MM									
Female NPT	1/8 in.	0.09	0.080 (2.0)	SS-ORF2	1.88 (47.8)	0.94 (23.9)		1.25 (31.8)	0.44 (11.2)	0.31 (7.9)	1.00 (25.4)	0.47 (11.9)	2.28 (57.9)
	1/8 in.	0.37	0.172 (4.4)	SS-1RF2	1.62 (41.1)	0.81 (20.6)		1.19 (30.2)		0.38 (9.7)	1.38 (35.1)	0.53 (13.5)	2.50 (63.5)
	1/4 in.	0.73	0.250 (6.4)	SS-1RF4	2.12 (53.8)	1.06 (26.9)		1.56 (39.6)	0.55 (14.0)	0.50 (12.7)	1.88 (47.8)	0.78 (19.8)	2.97 (75.4)
	3/8 in.	1.80	0.375 (9.5)	SS-18RF6	3.00 (76.2)	1.50 (38.1)		2.25 (57.2)	0.75 (19.1)		3.00 (76.2)	1.03 (26.2)	3.88 (98.6)
	1/2 in.			SS-18RF8									
Male NPT	1/8 in.	0.09	0.080 (2.0)	SS-ORM2	1.50 (38.1)	0.75 (19.1)		1.06 (26.9)	0.44 (11.2)	0.31 (7.9)	1.00 (25.4)	0.47 (11.9)	2.28 (57.9)
	1/8 in.	0.37	0.172 (4.4)	SS-1RM2	1.62 (41.1)	0.81 (20.6)		1.19 (30.2)		0.38 (9.7)	1.38 (35.1)	0.53 (13.5)	2.50 (63.5)
	1/4 in.			SS-1RM4	1.97 (50.0)	0.98 (24.9)		1.36 (34.5)					
	3/8 in.	0.73	0.250 (6.4)	SS-1RM6	2.25 (62.5)	1.12 (28.4)		1.62 (41.1)	0.55 (14.0)	0.50 (12.7)	1.88 (47.8)	0.78 (19.8)	2.97 (75.4)
	1/2 in.	1.80	0.375 (9.5)	SS-18RM8	3.00 (76.2)	1.50 (38.1)		2.25 (57.2)	0.75 (19.1)		3.00 (76.2)	1.03 (26.2)	3.88 (98.6)
Male NPT/ Swagelok tube fitting	1/8 in.	0.09	0.080 (2.0)	SS-ORM2-S2	1.73 (43.9)	0.98 (24.9)	0.75 (19.1)	1.29 (32.8)	0.44 (11.2)	0.31 (7.9)	1.00 (25.4)	0.47 (11.9)	2.28 (57.9)
	1/4 in.	0.37	0.172 (4.4)	SS-1RM4-S4	1.95 (49.5)	1.13 (28.7)	0.98 (24.9)	1.51 (38.4)		0.38 (9.7)	1.38 (35.1)	0.53 (13.5)	2.50 (63.5)
	1/4/ 3/8 in.	0.73	0.250 (6.4)	SS-1RM4-S6	2.42 (61.5)	1.29 (32.8)	1.12 (28.4)	1.79 (45.5)	0.55 (14.0)	0.50 (12.7)	1.88 (47.8)	0.78 (19.8)	2.97 (75.4)
	3/8 in.			SS-1RM6-S6		1.90 (48.3)							
	3/8/ 1/2 in.			SS-1RM6-S8	2.52 (64.0)	1.40 (35.6)							
Male/ female NPT	1/4 in.	0.73	0.250 (6.4)	SS-1RM4-F4	2.19 (55.6)	1.06 (26.9)	1.12 (28.4)	1.56 (39.6)	0.55 (14.0)	0.50 (12.7)	1.88 (47.8)	0.78 (19.8)	2.97 (75.4)
	1/2 in.	1.80	0.375 (9.5)	SS-18RM8-F8	3.00 (76.2)	1.50 (38.1)		2.25 (57.2)	0.75 (19.1)		3.00 (76.2)	1.03 (26.2)	3.88 (98.6)
Female ISO ^①	1/4 in.	0.73	0.250 (6.4)	SS-1RF4RT	2.12 (53.8)	1.06 (26.9)		1.56 (39.6)	0.55 (14.0)	0.50 (12.7)	1.88 (47.8)	0.78 (19.8)	2.97 (75.4)
	3/8 in.	1.80	0.375 (9.5)	SS-18RF6RT	3.00 (76.2)	1.50 (38.1)		2.25 (57.2)	0.75 (19.1)		3.00 (76.2)	1.03 (26.2)	3.88 (98.6)
	1/2 in.			SS-18RF8RT									

Dimensions determined using valves with regulating stems and standard handles. Dimensions are shown with Swagelok nuts finger-tight.

① See specifications ISO 7/1, BS EN 10226-1, DIN-2999, JIS B0203.

Ordering Information and Dimensions

20 and 26 Series

Dimensions are for reference only and are subject to change.

Select an ordering number.

For soft-seat stems and PCTFE stem-tips in valves that are standard with vee stems, replace **V** with **K**.

Example: SS-20KS4

Angle-Pattern Valves

Angle-pattern bodies are available for valves with C dimensions listed. To order, add **-A** to the ordering number.

Example: SS-20KM4-F4-A

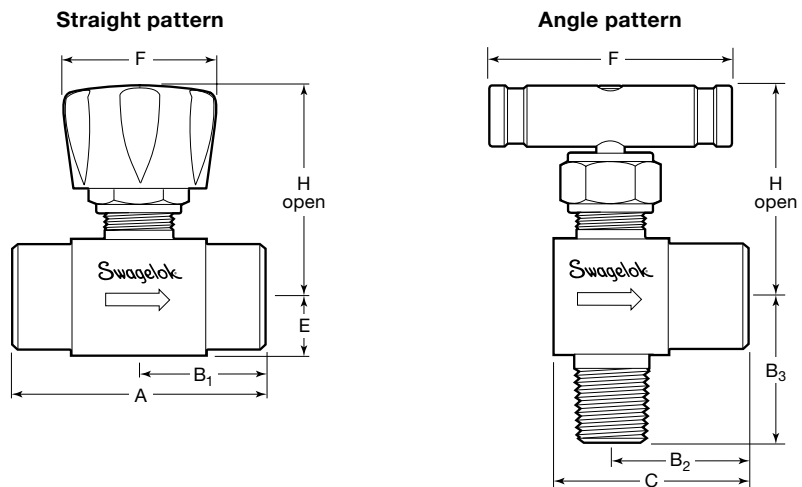

End Connections		C _v	Orifice in. (mm)	Ordering Number	Dimensions, in. (mm)									
Inlet/Outlet	Size				A	B ₁	B ₂	B ₃	C	E	F	H		
20 series with soft-seat stem and PCTFE stem tip														
Female NPT	1/4 in.	0.09	0.080 (2.0)	SS-20KF4	1.88 (47.8)	0.94 (23.9)	—	—	—	0.42 (10.7)	1.12 (28.4)	1.66 (42.2)		
Male NPT	1/4 in.			SS-20KM4	1.94 (49.3)	0.97 (24.6)	—	—	—					
Male/ female NPT	1/4 in.			SS-20KM4-F4	1.91 (48.5)	0.94 (23.9)	1.00 (25.4)	1.03 (26.2)	1.44 (36.6)					
20 and 26 series with vee stem														
Swagelok tube fittings	1/4 in.	0.21	0.125 (3.2)	SS-20VS4	2.46 (62.5)	1.23 (31.2)	1.13 (28.7)	1.16 (29.5)	1.57 (39.9)	0.42 (10.7)	1.75 (44.4)	1.66 (42.2)		
	3/8 in.	0.73	0.250 (6.4)	SS-26VS6	3.08 (78.2)	1.54 (39.1)	—	—	—	0.66 (16.8)	2.50 (63.5)	2.31 (58.7)		
	1/2 in.			SS-26VS8	3.30 (83.8)	1.65 (41.9)	—	—	—	—	—	—		
Female NPT	1/4 in.	0.21	0.125 (3.2)	SS-20VF4	1.88 (47.8)	0.94 (23.9)	1.00 (25.4)		1.44 (36.6)	0.42 (10.7)	1.75 (44.4)	1.66 (42.2)		
	3/8 in.	0.73	0.250 (6.4)	SS-26VF6	2.50 (63.5)	1.25 (31.8)	—	—	—	0.66 (16.8)	2.50 (63.5)	2.31 (58.7)		
	1/2 in.			SS-26VF8	2.50 (63.5)	1.25 (31.8)	1.41 (35.8)		2.06 (52.3)	—	—	—		
Male NPT	1/4 in.	0.21	0.125 (3.2)	SS-20VM4	1.94 (49.3)	0.97 (24.6)	—	—	—	0.42 (10.7)	1.75 (44.4)	1.66 (42.2)		
Male NPT/ Swagelok tube fittings	1/4 in.			SS-20VM4-S4	—	—	1.13 (28.7)	1.00 (25.4)	1.57 (39.9)	—				
Male/ female NPT	1/4 in.			SS-20VM4-F4	1.91 (48.5)	0.94 (23.9)	1.00 (25.4)	1.03 (26.2)	1.44 (36.6)	0.42 (10.7)			1.75 (44.4)	
	3/8 in.	0.73	0.250 (6.4)	SS-26VM6-F6	2.50 (63.5)	1.25 (31.8)	1.41 (35.8)	1.22 (31.0)	2.06 (52.3)	0.66 (16.8)	2.50 (63.5)	2.31 (58.7)		
	1/2 in.			SS-26VM8-F8	2.55 (64.8)	1.25 (31.8)	1.41 (35.8)						—	—
	3/4 to 1/2 in.			SS-26VM12-F8	2.50 (63.5)	1.25 (31.8)	—	—					—	—
Female ISO ^①	1/4 in.	0.21	0.125 (3.2)	SS-20VF4RT	1.88 (47.8)	0.94 (23.9)	—	—	—	0.42 (10.7)	1.75 (44.4)	1.66 (42.2)		
	1/2 in.	0.73	0.250 (6.4)	SS-26VF8RT	2.50 (63.5)	1.25 (31.8)	—	—	—	0.66 (16.8)	2.50 (63.5)	2.31 (58.7)		

Dimensions are shown with Swagelok nuts finger-tight.

① See specifications ISO 7/1, BS EN 10226-1, DIN-2999, JIS B0203.

Options and Accessories

Stem Packing Materials

Two-piece chevron-style PFA packing is standard. For an optional stem packing, add **-P** for UHMWPE or **-PK** for PEEK to the ordering number. See **Pressure-Temperature Ratings**, page 2, for ratings of valves with optional stem packings. See the table at right for lubricants used with optional stem packing materials.

Examples: SS-ORS2-**P**
SS-20KF4-**PK**

Stem Packing Kits

PFA, UHMWPE, and PEEK packing kits are available. Kits contain stem packings, springs, lubricant, and instructions.

Valve Series	Orifice in. (mm)	Stem Packing Material, Kit Ordering Number		
		PFA	UHMWPE	PEEK
O	All	PFA-91K-O	PE-91K-O	PK-91K-O
1	0.172 (4.4)	PFA-91K-14	PE-91K-14	PK-91K-14
	0.250 (6.4)	PFA-91K-16	PE-91K-16	PK-91K-16
18	All	PFA-91K-18	PE-91K-18	PK-91K-18
20	All	PFA-91K-20	PE-91K-20	PK-91K-20
26	All	PFA-91K-16	PE-91K-16	PK-91K-16
Lubricant		Tungsten disulfide and fluorocarbon based	Molybdenum disulfide and hydrocarbon based	Molybdenum disulfide, tungsten disulfide, and fluorocarbon based

O-Ring Stem Seals

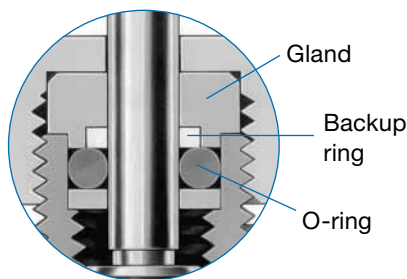

O-ring stem seals include:

- 316 SS/ASTM A276 gland for 316 SS, steel, and alloy 400 valves, or brass 360 gland for brass valves
- PTFE/ASTM D1710 backup ring and silicone-based lubricant for all O-rings except ethylene propylene, which requires a polyethylene/ASTM D4020 backup ring, and molybdenum disulfide with hydrocarbon-based lubricant
- O-ring.

O-Ring Material	Temperature Rating °F (°C)	O-Ring Designator	Kit Designator	Kit Basic Ordering Number
Buna C	-65 to 250 (-53 to 121)	-BC	BC70	-9K-O (O and 20 series) -9K-14 (1 series, 0.172 in. orifice) -9K-16 (1 series, 0.250 in. orifice) -9K-18 (18 series)
Buna N	-20 to 250 (-28 to 121)	-B	BN70	
Ethylene propylene		-E	EP70	
Fluorocarbon FKM	-20 to 450 (-28 to 232)	-V	VA70	
Kalrez®	10 to 350 (-12 to 176)	-KZ	KZ00	
Silicone	-20 to 250 (-28 to 121)	-SI	SI70	

Valves with O-Ring Stem Seals

Add an O-ring designator to the ordering number.

Examples: SS-ORS2-**BC**
SS-20KF4-**B**

O-Ring Maintenance Kits

Maintenance kits contain O-ring, backup ring, lubricant, and instructions.

To order, add a kit designator to a kit basic ordering number.

Example: **BC70-9K-O**

Options and Accessories

Handles

- O and 1 series valves—black phenolic round handles are standard; colored phenolic, 316 SS bar, and anodized black aluminum bar handles are optional.
- 18 series valves—anodized black aluminum bar handles are standard; phenolic round and 316 SS bar handles are optional.

Valves with Optional Handles

Add a handle designator to the ordering number.

Handle	Designator (O and 1 Series)	Designator (18, 20, and 26 Series)	Kit Color Designator
Black phenolic	-BK	-BKP	-BK
Blue phenolic	-BL	-BLP	-BL
Green phenolic	-GR	-GRP	-GR
Orange phenolic	-OG	-OGP	-OG
Red phenolic	-RD	-RDP	-RD
Yellow phenolic	-YW	-YWP	-YW
316 SS bar	-SH	-SH	—
Anodized black aluminum bar	-BKB	-BKB	—

Examples:
 SS-ORS2-**BL**
 SS-20KF4-**SH**

Sour Gas Service

Integral-bonnet needle valves with female NPT, female ISO, and male NPT end connections are available for sour gas service. Stem and lower gland are alloy 400. Materials are selected in accordance with NACE MR0175/ISO 15156. See the NACE specification for information on stainless tube fitting requirements.

To order, add **-SG** to the ordering number.

Example: SS-ORF2-**SG**

Special Cleaning and Packaging (SC-11)

To order integral-bonnet needle valves cleaned and packaged in accordance with Swagelok *Special Cleaning and Packaging (SC-11)*, MS-06-63, to ensure compliance with product cleanliness requirements stated in ASTM G93 Level C, add **-SC11** to the valve ordering number.

Example: SS-ORS2-**SC11**

Safe Product Selection

When selecting a product, the total system design must be considered to ensure safe, trouble-free performance. Function, material compatibility, adequate ratings, proper installation, operation, and maintenance are the responsibilities of the system designer and user.

Caution: Do not mix or interchange parts with those of other manufacturers.

- 20K series valves—anodized black aluminum knob handles are standard; phenolic round, 316 SS bar, and anodized black aluminum bar handles are optional.
- 20V and 26 series valves—316 SS bar handles are standard; phenolic round and anodized black aluminum bar handles are optional.

Handle Kits

Handle kits contain handle and instructions. Select a handle kit ordering number.

For colored phenolic handles, replace **BK** in the ordering number with a kit color designator.

Valve Series	Orifice in. (mm)	Handle Kit Ordering Numbers		
		Black Phenolic	Black Aluminum Bar	316 SS Bar
O	All	PH-5K-OK-BK	A-5K-14B-BK	SS-5K-14B
1	0.172 (4.4)	PH-5K-14K-BK	A-5K-14B-BK	SS-5K-14B
	0.250 (6.4)	PH-5K-4K-BK	A-5K-6NB-BK	SS-5K-6NB
18	All	PH-5K-7K-BK	A-5K-18B-BK	SS-5K-7B
20	All	PH-5K-14K-BK	A-5K-14B-BK	SS-5K-14B
26	All	PH-5K-4K-BK	A-5K-6NB-BK	SS-5K-6NB

Example: PH-5K-OK-**BL**

To order an anodized black aluminum knob handle kit for the 20K series valve, use ordering number **A-5K-20K-BK**.

Oxygen Service Hazards

For more information about hazards and risks of oxygen-enriched systems, see the Swagelok *Oxygen System Safety* technical report, MS-06-13.

- ⚠ **A packing adjustment may be required periodically to increase service life and to prevent leakage.**
- ⚠ **Valves that have not been cycled for a period of time may have a higher initial actuation torque.**
- ⚠ **To increase service life, ensure proper valve performance, and prevent leakage, apply only as much torque as is required to achieve positive shutoff.**

Warranty Information

Swagelok products are backed by The Swagelok Limited Lifetime Warranty. For a copy, visit swagelok.com or contact your authorized Swagelok representative.